



Enhancing Paralysis Patient Care through an IoT-Enabled Healthcare Ecosystem

G. Shanmugaraj^{1*}, Shaik Mariam Fathima², Alluri Gnapika³, K. Mohanambal⁴

^{1,2,3}Department of ECE Velammal Institute of Technology, Chennai, India, Anna University

⁴Department of CSE, Velammal Engineering College, Chennai, India, Anna University

*Corresponding author: G. Shanmugaraj, Department of ECE Velammal Institute of Technology, Chennai, India, Anna University, Email: gsraj76@gmail.com

Submitted: 22 March 2023; Accepted: 19 April 2023; Published: 12 May 2023

ABSTRACT

Magnifying the healthcare system leads to the success of the country. IoT facilitates monitoring the Health of the patient's in problem-solving time, thus considerably slitting down the need less visits to doctors, hospital stays, and re-admissions. As we all know that paralysis patients will not be able to convey their needs largely because most of the parts of the body are not movable. Here we come up with a device that is an Accomplishing the needs of the paralysis patient using IoT. This system is advantageous for paralysis patients for both literates and illiterates to who are all able to hear, see and smell it is easily able to be understood for them which is helpful for them to convey their basic needs like Food, Water, and Washroom along with emergency via tilting their finger in distinct directions. This device is based on using the microcontroller rather than raspberry pi. When instantly a motion signal is received through the accelerometer it will be displayed on the LCD plus a buzzer sound will be heard also a message will be sent through GSM to the caretakers regarding any of the needs and emergencies as well as doctor receives a message in critical condition.

Keywords: LCD, GSM, Microcontroller, IoT, Buzzer Sound, Paralysis

INTRODUCTION

IoT plays a vital role in the present and in Modern days it helps to track the Patient's health condition for both doctors and physicians by using different techniques, sensors, etc which helps in collecting and exchange of data. It always helps doctors to be watchful and connected to patients so that life will be saved through seamless communication.

Paralysis occurs mainly due to spinal cord injury, Nerve disease, stroke and many other causes these patients can have the ability to see, hear and smell but they can't move their body

parts dues to no control over their tissues[1]. Paralysis mostly occurs due to severe brain damage and spinal cord injury here the brain neither sends nor receives signals to parts of the body it's challenging for the patient to be recovered. And the devices or equipment that are being used in hospitals are also difficult to buy or get home and hard to understand to use them. It is a strenuous task for a nurse or a doctor to always stay near the patient most of the time even after getting discharged from the hospital it's hard to notice and to know their needs and their internal problems as patients can't express them directly here normal people will not be able to understand

their basic needs and problems this is a critical job to save the patient in case of emergency in absence of nurse or doctor. And some devices are present which are not affordable for low-level people so they are hopeless in serving the patient and to care them properly.

Here the IoT breaks ground by providing a solution to people who are enduring from paralysis. In order to vanquish this situation a device is proposed which supports two different types of paralysis patients like Hemiplegia which affects only one side of the body, Monoplegia here only one limb or leg is paralyzed and Paraplegia where the paralysis is affected for both legs one important note is this is not suitable for Tetraplegia patients. And this device is of low cost, and fragile as compared to other equipment, and usage of this device will be easily understood by the young generation to the old generation. This device is introduced by considering to be time ahead so that the patient necessities will be well pleased. This is a communication device additionally this can also be used by old people who are not able to convey their needs properly. And also there is a similar device to this which is made of using Raspberry pi but this device that is here said about is made of using a microcontroller and software simulation and still a few other components. This device is introduced by considering to be time ahead so that the patient necessities will be well pleased [2,3]. This is a communication device additionally this can also be used by old people who are not able to convey their needs properly. And also there is a similar device to this which is made of using Raspberry pi but this device is made of using the Arduino nano plus software and still a few other components[4].

Existing System

For a person who is entirely paralyzed, a system with a temperature sensor to track the patient's body temperature and a pulse oximeter to measure blood oxygen levels and the patient's pulse is described in one of the paper [13]. In another work, a person who is entirely paralyzed is given a human computer interface. The eye blink sensor and eye motion detection sensor handle these kinds of scenarios. The sensor,

which is set up close to the eye and detects eye movement and blinking and then encodes this information into a specific input, is used. The S.O.S. signal is transmitted in case of an emergency [14].

In another study, flexible sensors were employed to operate robotic devices using precise finger motions that were used to carry out specified activities this is used for patient assistance. The sensor may become melted if there is a lot of heat produced over a lengthy period of time [12]. In another author proposed a system in which all of the sensors would be directly linked to the Raspberry Pi, which would then show the calculated outputs, sound the alarm in the event of any risks, send out emails and text messages, and also maintain a cloud display and database for further usage of the data. The names and dosage units of the prescription drugs will be shown, which is an intriguing element of this system.

The prospects and difficulties for IoT in implementing the idea of the next phase of health care were highlighted by another author. He suggested that wearable sensors may easily include many physiological parameters, allowing for the storage of data with a considerably higher sampling rate over a much longer period of time. A device that measures heart rate and body fat using the LPC 2129 ARM Processor Development Board was proposed by another researcher. Data were sent over wireless networks to a website server and then shown on a web page.

Numerous healthcare monitoring systems are on the market, but they have a variety of limitations, such a lack of power efficiency, bulkiness, wired setup, delayed reaction, etc[8,9]. It is a thorough analysis that is highly beneficial for comprehending IoT networks and how they operate. Wireless wearable technology is a great way to get around .

Proposed system

This proposed project mainly helps in accomplishing the needs of the paralysis patient as there is no such device that exists so this device will be useful for the patient where there is no

movement in a few of their body parts like normal people. It's hard for them to express their essentials like food, water, wash room plus to express the problem or discomfort that they are facing internally is so hard to understand for normal people who stay near the patient. The design of this model will be very helpful for people with partial paralysis conditions like hemiplegia, which affects one arm and one leg on the identical side of the body, monoplegia, which affects one arm or leg, and paraplegia, which affects both legs. However, this design will not be helpful for people with tetraplegia, which interferes with both legs and arms. So, With the aid of motion gestures, this gadget enables users to just move their finger to show the message on the Liquid crystal display and a buzzer sound also will be heard and a message will be sent to the patient's family members and doctor.

Working system

Depending on how the device is tilted, the message is delivered in a different way. In this case, an accelerometer is used to measure the motion statistics. The microcontroller receives this information after that. The microcontroller

interprets the input and displays the particular message after processing the data. Now, the microcontroller displays the corresponding message on the LCD panel. It also produces a buzzer-like sound and a message as soon as it receives a motion signal from the accelerometer. Initially, if the patient doesn't need anything, the text displayed on LCD will be as "No Message"; here we will not get any buzzer sound or message. In one instance if the patient desires "Food", he must point his finger in the forward direction. In another instance, the patient must tilt his finger to the left if he wants "water". If the patient wishes to use the "Restroom" in the third instance, he must advance his finger to the right direction. In each of the aforementioned instances, the family members will receive a message, which will be shown on the LCD screen and audibly buzzed. Last but not least, the patient should move their finger backward to indicate any inside discomfort. The buzzer will sound, the word "emergency" will appear on the LCD, and a message informing the patient's family and the doctor of their serious situation will be sent. This device also has additional buttons so that the patient who is able to press a button can do so Fig[1].

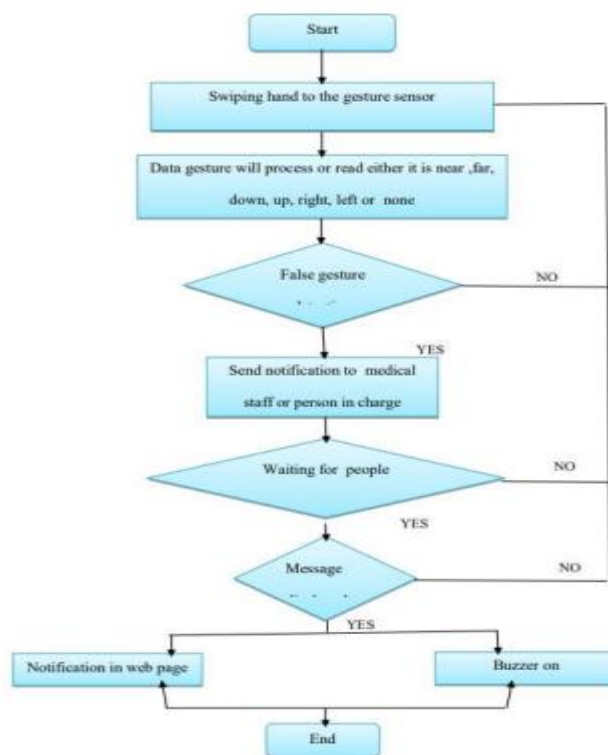

FIG 1. Flow chart of system Working

TABLE 1: Accelerometr values for glove

Motion of the glove	Indication Accelerometer	Representation of magnitude in accelerometer	Message in LCD Display/IoT
Case1:Glove in normal position	due to the forces of gravity of the earth, remains unchanged.	The accelerometer's values of x and y coordinates will be both 0.	NORMAL
Case 2 : Backward motion of the glove	The accelerometer moved upwards in an angle that is positive in magnitude in relation to the earth's gravitational attraction.	The accelerometer's y coordinates range from 0 to 5 (0 to +5).	EMERGENCY
Case3: Rightward motion of the glove	The accelerometer moved in a vertical direction with a negative value, parallel to the earth's gravitational force.	The accelerometer's y coordinate values fall between zero and five (-5 to 0)	RESTROOM
Case 4: forward movement of glove	In relation to the gravitational pull of the earth, the accelerometer has progressed in the positive direction across its horizontal axis.	The accelerometer's x-coordinate values fall between zero and five (0 to 5)	NEED FOOD
Case5: Leftward movement of glove	The horizontal axis of the accelerometer is at negative magnitude with reference to the gravitational pull of the earth.	The accelerometer's x coordinate values fall between zero and five (0 to 5)	NEED WATER

System Description

Transmitter

Two switches that are properly linked to the microcontroller and brought up to 5V serve as the microcontroller's input instruction. We also received an LCD monitor for showing the transferred data. Additionally, we have a set-up that allows the clock and data pin from a computer keyboard to be linked for positive and negative portions. This data is then connected as an input to the microcontroller from the keyboard's output, and is finally shown in the

LCD. There is also an RF transmitter here. It has a GND and VCC supply. The microcontroller receives data on the data pin. Because of how the programme is built, activating the keyboard comes first when using it properly. An accelerometer tracks the data that change when the gloves tilt. The accelerometer provides information about the corresponding shift in axis measurements to the Arduino Nano. At this point, the encoder is fed axis readings through data input ports. The encoded data is retrieved using the encoder's Dout pin Fig[2].

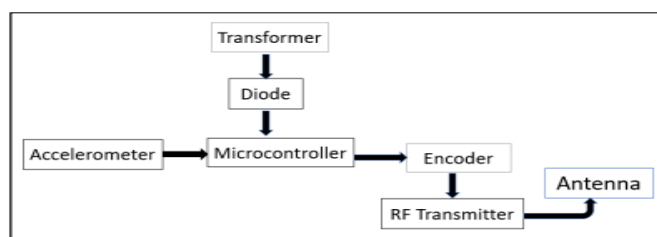

FIG 2: Transmitter Diagram.

This data serve as a representation of the message that must be sent.

Receiver

The RF receiver module, an Arduino Nano, an LCD display, a decoder circuit, a buzzer, a Wi-Fi module that connects to the IoT cloud, and a copper coil antenna make up the receiver part. The receiver starts working when the copper coil antenna is connected to pin 8 of the receiver. When the data transmitted by the copper coil

antenna on the transmitter side is received, it sends the data to the RF Receiver module. Pins 1, 6, as well as 7 of the receiver's eight pins, were rooted. The VDD pin of the decoder, which is of 5Volts, is linked to jacks 4 and 5 of a receiver module. The decoder has 4 output pins that deliver the output created by the message's decoding function Fig[3].The Arduino Nano receives the info output generated by the decoder. Here we can see that Arduino Nano is indeed connected to a buzzer.

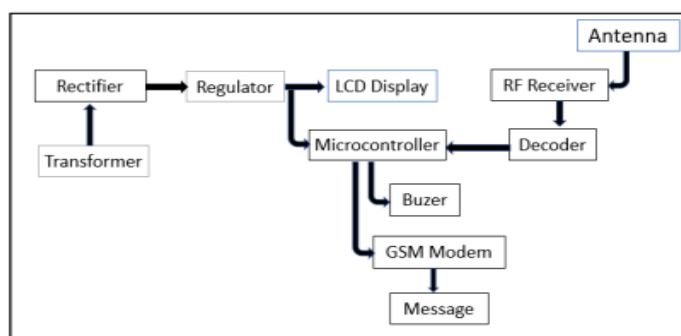

FIG 3: Receiver Diagram.

For cloud messaging capability, an Arduino Nano is coupled to an ESP8266 Node MCU Wi-Fi module. The +3.3V pin of the Arduino Nano is linked to the VCC pin of the ESP8266. The Wi-Fi module's TX pin is linked to pin D2 of the Arduino Nano, while its RX pin is attached to pin D3 of the same board. The message that will be shown is uploaded to the cloud via the Wi-Fi

module. The LCD display module is now showing the message that the patient is supposed to communicate.

Implementation Setup

RF Transmitter and RF Receiver

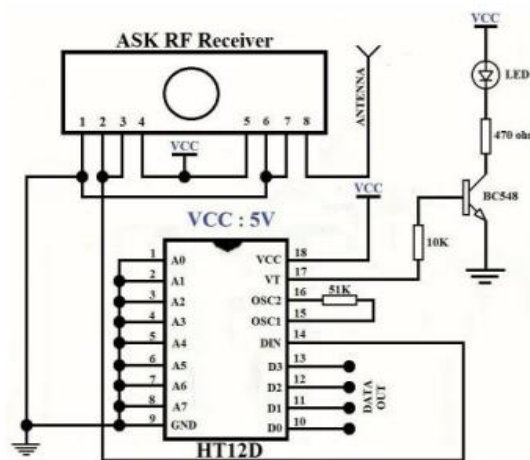

FIG 4: RF Receiver

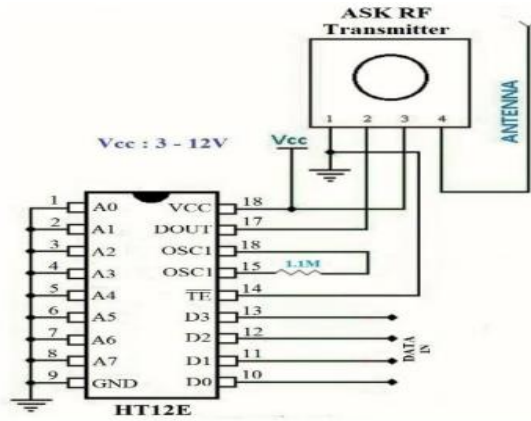

FIG 5: RF Transmitter

The Rf module must be able to transmit information at a specific data rate and over a specified distance.

Three pins, designated as Vcc, Din, and ground, make up the transmitter module Fig[4]. The input voltage range for the Vcc pin is large, ranging from 3V to 12V. During transmission, the transmitter uses a minimum of 9mA and a maximum of 40mA of current. The data pin used to transmit the signal is located in the centre. ASK is used to modulate this signal before it is

transmitted over the air at a frequency of 433MHz.

As previously mentioned, the RF receiver module contains four pins: Vcc, Dout, Linear out, and Ground Fig[5]. A controlled 5V supply should be used to power the Vcc pin. This module's operational current is less than 5.5mA. To receive the 433Mhz signal from the air, the pins Dout and Linear out are shorted together. Next, this signal is demodulated to get the data and sent out through the data pin.

RESULT

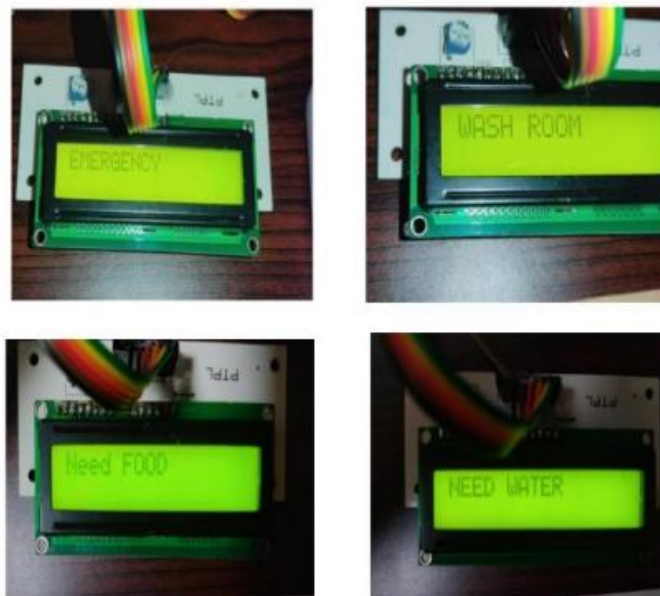

FIG 6: Output and Result on LCD

To get the text on the LCD to appear and a message to be sent if the patient desires food, he must tilt his finger in the right direction Fig[6].

The patient must tilt his finger to the left in order for the text to appear on the LCD and a message to be sent if he desires water Fig[6].

The patient must move his finger forward in

order for a text to be displayed on the LCD and a message to be sent if he wishes to go to the restroom Fig[6].

If the patient needs to communicate an inside issue or pain, he must move his finger in the rear direction. The term "emergency" will then be displayed on the LCD, and a message will be sent Fig[6].

Initially this Message is displayed on Mobile

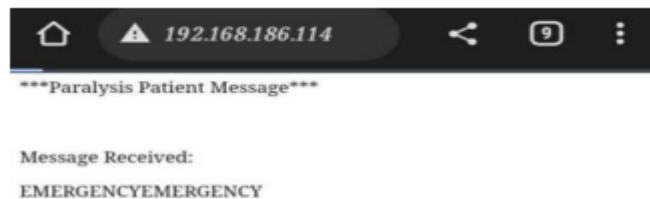

If tilted backward this Message is displayed on Mobile

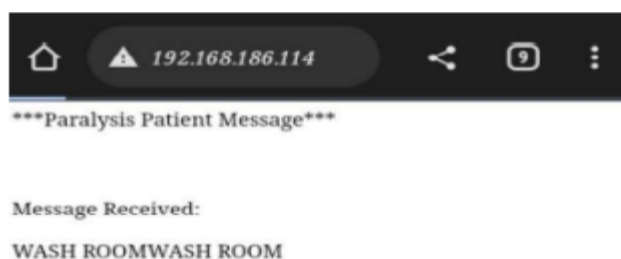

If tilted in Right direction this message is displayed on mobile

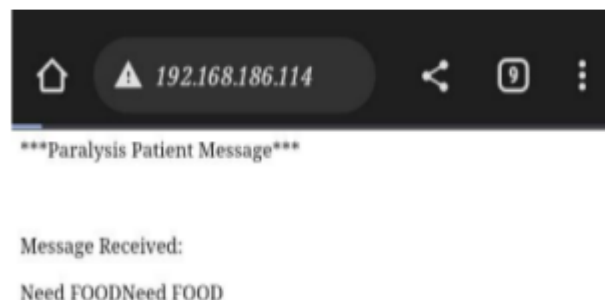

If tilted in forward direction this message is displayed on mobile



If tilted in left direction this message is displayed on mobile

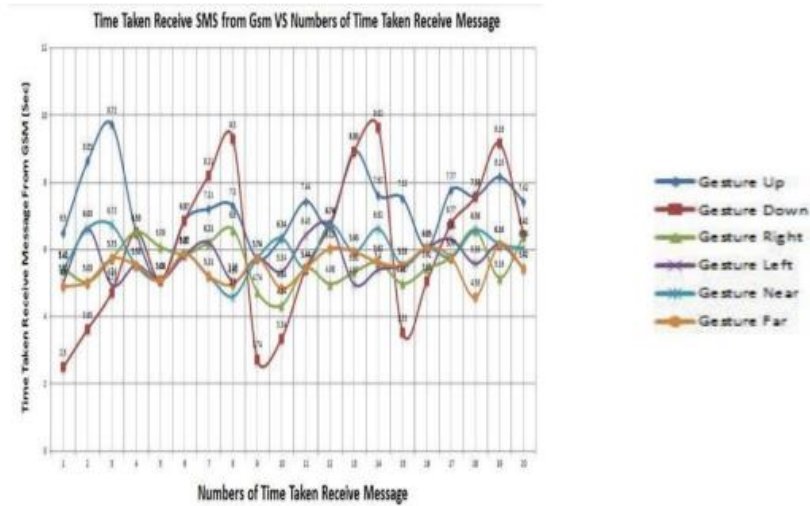

FIG 7 : Graph the time taken receive SMS vs. number of time taken receive message

This tells about the duration of SMS receipt and the total duration of messages received when the patient tilts his finger when he needs to express his basic needs Fig[7].

Analysis and Performance of System

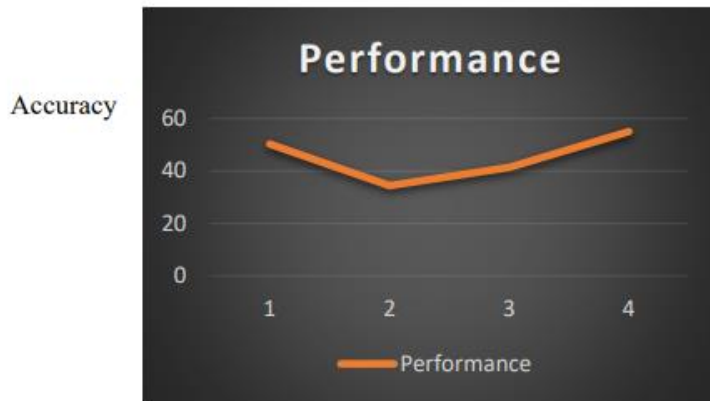

FIG 8: Accuracy of System working

When the battery power was adequate, the outputs were quite accurate and the signal strength was very high. These fluctuations in the graph show how the system worked at various times. When the battery's power was low, the results weren't as precise and took longer than they did before. A fully charged battery is necessary for the system to operate effectively. It demonstrates that accurate outcomes and quick responses are both expected. Even if the power

varies, the results won't be accurate and will either be incorrect or won't be displayed. In order to produce the intended output, all linkages and movements must be obvious.

As we see the Fig[15] here initially when 60 times the gesture is given then the system worked accurately but when gesture value increases the accuracy of the devices decreases again after

checking or changing its battery the accuracy being increased.

CONCLUSION

Patients with paralysis can achieve movement independence thanks to this technology. They can seek for assistance when they do. Patients whose entire or a portion of their bodies have been crippled by a paralysis attack.

since they are neither able to talk clearly nor use sign language. In such a case, we suggest a system that enables a paralysis person to display a message on the LCD and a buzzer sound by merely moving any part of his body that is capable of motion.

This system also handles the case where the patient is alone and no one is available to care he needs to say through via SMS. This will communicate the patient's fundamental needs, such as those for food, drink, restroom use, and emergency circumstances. These folks require a variety of supports, and it is our responsibility as aspiring engineers to create innovative solutions to assist paralyzed patients. Patients with paralysis can significantly benefit from this device

Future Work

Future project objectives: By making the goggle wireless for eyeblink detection in the future, the system may be made smart and effective. Technology like as Bluetooth and Wi-Fi can be used to create it. to make the system user-friendly, secure, and efficient. Moreover, various security indicators, such as light indicators, can be incorporated for continuous patient monitoring. Instead of utilising a GSM module, check the patient's vitals on a mobile device if they are at the hospital. As a result, it is helpful in hospitals for ongoing bodily parameter monitoring on a doctor's mobile or the primary mobile of the hospital ward. More parameters may be felt and monitored in accordance with the availability of sensors or advancements in biomedical trends, which will significantly increase the effectiveness of wireless monitoring system.

REFERENCES

1. Assistance system for paraplegic," Abhijeet Botre et al, appeared in International Journal of Innovative Research in Electrical, Electronics, Instrumentation, and Control Engineering, Volume 4, Issue 5(2016).
2. Rolga Roy, S. Archa, Josny Jose, and Rinku Varghese, "A survey on different methodologies to Assist paralyzed patients", International Journal of Advanced Research in Electrical, Electronics and Instrumentation Engineering, vol.5, Issue.3, pp.1281-1285, March 2016.
3. Shifali Gupta, " Android Based Mobile Drive System", International Journal of Advances in Electronics and Computer Science, vol.5, Issue.6, pp. 24-27, June 2018.
4. K. Seena Naik and E. Sudarshan "Smart Health Care Monitoring System using a raspberry pi on IoT Platform" ARPJ Journal of Engineering and Applied Sciences, vol. 14, No. 4, February 2019.
5. Alyson Matheus de Carvalho Souza et al, "Hand Copter Game".It was released in virtual and augmented reality (SVR), in 2012.
6. Ismail. S., "Advantages and Disadvantages of Using Arduino," Engineer Experience. Retrieved from <http://engineerexperiences.com/advantages-and-disadvantages.html>, 2016.
7. Huzaimy, M., "Wi-Fi and GSM Based Motion Sensor for Home Security System Application," 4th International Conference on Electronic Devices, System and Applications, 2015
8. N. Birbaumer, A. Kübler, N. Ghanayim, T. Hinterberger, J. Perelmouter, J. Kaiser, I. Iversen, B. Kotchoubey, N Neumann, H. Flor, "The Thought Translation Device (TTD) for Completely Paralyzed Patients", IEEE Transactions on Rehabilitation Engineering, vol. 8, No. 2, pp. 190-193, June 2000
9. B. B. Edin et al, "Bio-Inspired Sensorization of a Biomechatronic Robot Hand for the Grasp and-Lift Task", Brain Research Bulletin, vol. 75, Issue 6, pp. 785-795, 15 April 2008.
10. T. Deepasri, M. GokulPriya, G. Arunkumar, P. Mohanraj, and M. Shenbagapriya, "Automated Paralysis Patient Health Care Monitoring System", South Asian Journal of Engineering and Technology vol. 3, No. 2, pp. 85-92, 2017.
11. V. Viancy, J. Avinash Wilson, and P. Anusha, "Paralyzed Patient Monitoring Equipment – IoT", International Journal of Advanced Research in Basic Engineering Sciences and Technology, Vol.6, Issue.10, October 2020.
12. Kollu Jaya Lakshmi, Akshada Muneshwar, A Venkata Ratnam and Prakash Kodali," Patient Assistance using Flex Sensor", Published in: 2020

- International Conference on Communication and Signal Processing (ICCSP), July, 2020.
13. Vikram Singh R. Parihar¹, Akesh Y. Tonge², Pooja D. Ganorkar,” Heartbeat and Temperature Monitoring System for Remote Patients using Arduino”, International Journal of Advanced Engineering Research and Science, 2016.
 14. Milan Pandey et al, “Assistance for Paralyzed Patient Using Eye Motion Detection”, Fourth International Conference on Computing Communication Control and Automation, ©2018 IEEE.
 15. K. Seena Naik and E. Sudarshan “Smart Health Care Monitoring System using a raspberry pi on IoT Platform” ARPN Journal of Engineering and Applied Sciences, vol. 14, No. 4, February 2019.